

**Automatic Transmission**

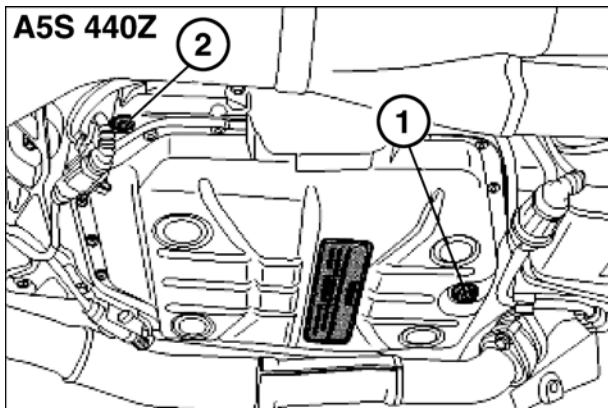
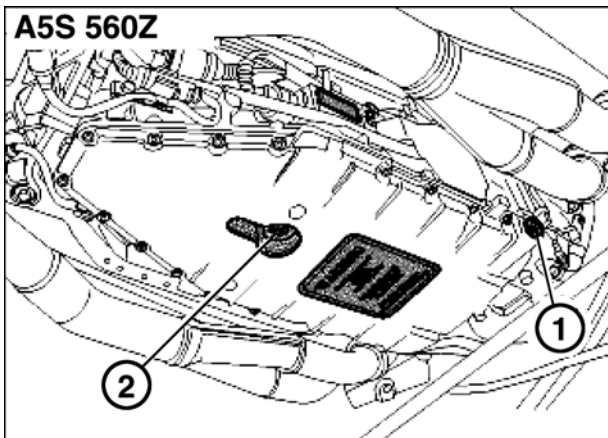
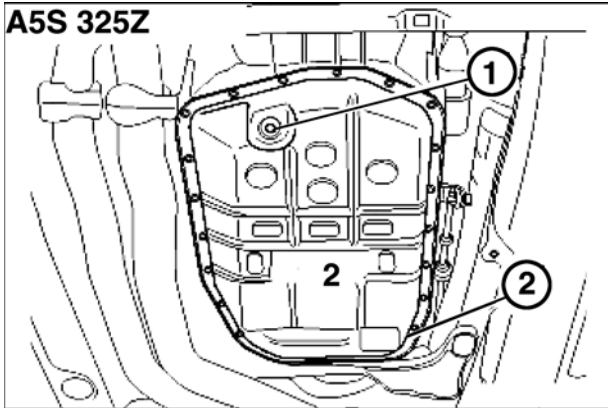

**NOTE—**

Use new ATF pan bolts purchased from BMW. Alternatively, clean old bolts and coat with Loctite® thread locking compound or equivalent.

**Automatic transmission fluid capacity**

**A4S 310R**

with torque converter	8.8 liters (9.3 US qt)
without torque converter	7.8 liters (8.3 US qt)

**A5S 360R / A5S 390R**

with torque converter	9.0 liters (9.5 US qt)
without torque converter	8.0 liters (8.5 US qt)

**A5S 325Z (2.5 liter engine)**

with torque converter	8.9 liters (9.4 US qt)
without torque converter	6.2 liters (6.5 US qt)

**A5S 325Z (3.0 liter engine)**

with torque converter	8.7 liters (9.3 US qt)
without torque converter	6.1 liters (6.4 US qt)

**A5S 560Z**

with torque converter	13.1 liters (13.8 US qt)
without torque converter	5.5 liters (5.8 US qt)

**A5S 440Z**

with torque converter	9.0 liters (9.5 US qt)
without torque converter	5.35 liters (5.7 US qt)

**Tightening torques**

**ATF drain plug to ATF pan**

A4S 310R	33 Nm (24 ft-lb)
A5S 360R / A5S 390R (M14)	20 Nm (15 ft-lb)
A5S 325Z	35 Nm (26 ft-lb)
A5S 560Z	50 Nm (37 ft-lb)
A5S 440Z (M16)	30 Nm (23 ft-lb)

**ATF fill plug to transmission housing**

A4S 310R	25 Nm (18 ft-lb)
A5S 360R / A5S 390R (M14)	20 Nm (15 ft-lb)
A5S 325Z	30 Nm (23 ft-lb)
A5S 560Z	100 Nm (74 ft-lb)
A5S 440Z (M18)	35 Nm (26 ft-lb)

**ATF pan to transmission (M6)**

A4S 310R	12 Nm (9 ft-lb)
A5S 360R / A5S 390R	10 Nm (7 ft-lb)
A5S 325Z	6 Nm (4 ft-lb)
A5S 560Z	10 Nm (7 ft-lb)
A5S 440Z	10 Nm (7 ft-lb)