

ATF service—A4S 310R

A4S 310R transmissions may or may not be fitted with a dipstick. Early versions of the A4S 310R were equipped with a dipstick. On later models, the dipstick was eliminated.

On cars without an ATF level dipstick, it is recommended that ATF level checking be left to authorized BMW dealer with the appropriate temperature measuring equipment. The most accurate check of the ATF level is best done on a lift with the engine running in neutral and the ATF at a specific temperature.

WARNING —

The ATF should be warm when draining. Do not drain the ATF if the engine and/or transmission is hot. Hot ATF can scald.

1. Remove dipstick, where applicable.
2. Remove drain plug and drain fluid into container. See Fig. 24.

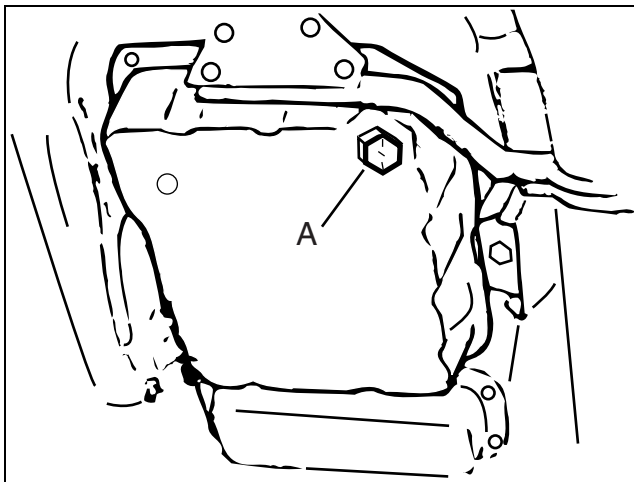

0011595

Fig. 24. ATF drain plug (A) on A4S 310R.

3. Remove rear (large) oil sump mounting bolts and remove sump and sump gasket.

NOTE —

The A4S 310R uses inch bolts, not metric bolts.

4. Remove strainer mounting screws and remove strainer together with gasket. See Fig. 25.

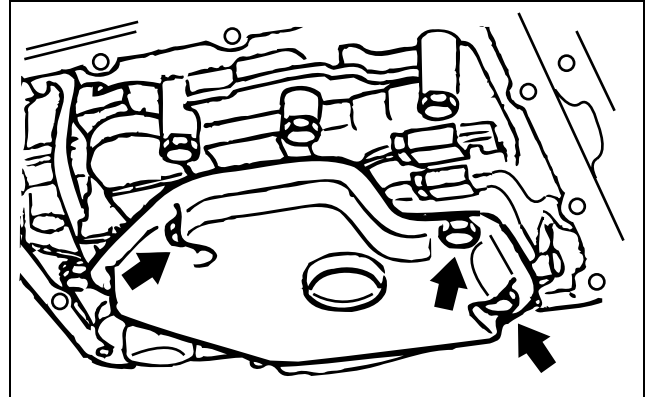

0011596

Fig. 25. ATF fluid strainer mounting bolts (arrows) on A4S 310R.

Installation is the reverse of removal. Always replace the drain plug seal and all gasket(s). Clean the sump and the sump magnet using a lint-free cloth. Use new bolts at the sump and tighten the bolts in-line, one after the other (i.e. do not tighten the bolts in a cross-wise pattern). Fill the transmission with the specified amount of fluid. See Fig. 24.

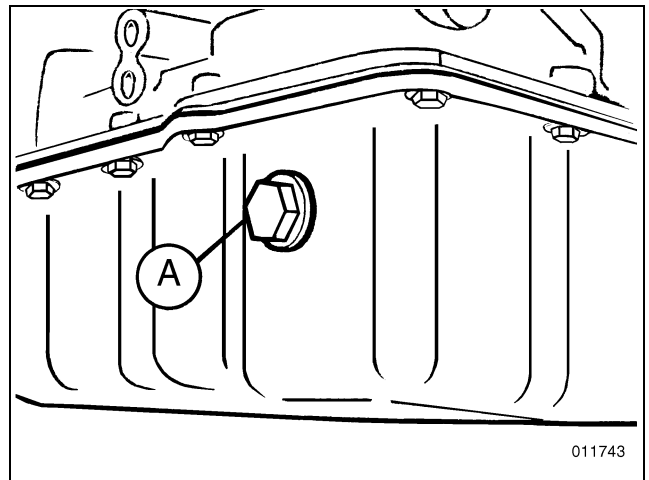

011743

Fig. 26. ATF fill plug (A) on A4S 310R.

NOTE —

- *On cars with ATF level dipstick, check the ATF level using Fig. 27 and Table e. The fluid level should only be checked with car on level surface and unloaded.*
- *On cars without ATF level dipstick, the car must be on level surface and unloaded, preferably on a lift. With the ATF at a temperature of 30-55°C (86-131°F), remove the ATF filler plug. Place the transmission in neutral and start the engine. With the ATF at the specified temperature, add ATF until it spills from the filler hole. Reinstall the filler plug.*

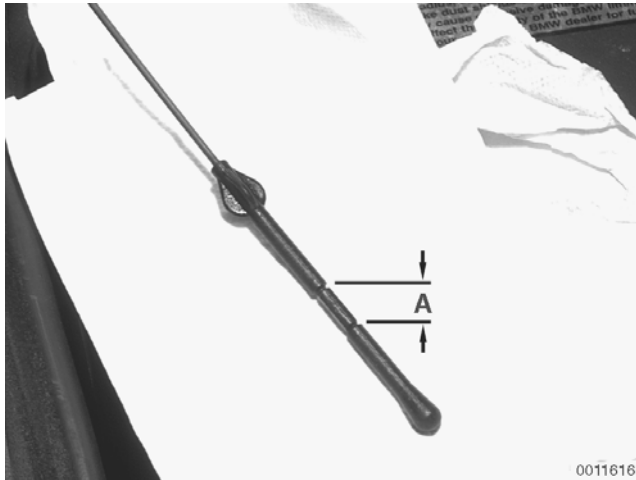

Fig. 27. ATF dipstick on A4S 310R transmission. Fluid level is indicated at A.

Tightening Torques

- ATF drain plug to ATF sump 25 Nm (18 ft-lb)
- ATF strainer to valve body 5 Nm (44 in-lb)
- ATF sump to transmission 12 Nm (9 ft-lb)

ATF specification

- Oil change volume (Dexron II) (removal of both sumps, w/o torque converter drain) 7.8 L (8.2 qt.)

Table e. ATF Level vs. Temperature – A4S 310R

ATF temperature	Oil level at dipstick (A in Fig. 26)	
	Minimum	Maximum
20°C (68°F)	3 mm (0.12 in.)	15 mm (0.60 in.)
25°C (77°F)	5 mm (0.20 in.)	17mm (0.67 in.)
30°C (86°F)	8 mm (0.31 in.)	20 mm (0.78 in.)
35°C (95°F)	11 mm (0.43 in.)	22 mm (0.87 in.)
40°C (104°F)	13 mm (0.51 in.)	25 mm (0.98 in.)
45°C (113°F)	14 mm (0.55 in.)	26 mm (1.02 in.)
50°C (122°F)	16 mm (0.63 in.)	27 mm (1.06 in.)
55°C (131°F)	17 mm (0.67 in.)	28 mm (1.10 in.)
60°C (140°F)	19 mm (0.74 in.)	29 mm (1.14 in.)
65°C (149°F)	21 mm (0.83 in.)	32 mm (1.26 in.)
70°C (158°F)	22 mm (0.87 in.)	34 mm (1.34 in.)
75°C (167°F)	24 mm (0.94 in.)	36 mm (1.42 in.)
80°C (176°F)	26 mm (1.02 in.)	38 mm (1.50 in.)
85°C (185°F)	29 mm (1.14 in.)	41 mm (1.61 in.)
90°C (194°F)	31 mm (1.22 in.)	43 mm (1.69 in.)

ATF service–A5S 310Z

The A5S 310Z transmission is not fitted with an ATF level dipstick. Therefore, it is recommended that ATF level checking be left to authorized BMW dealer with the appropriate tem-

perature measuring equipment. The most accurate check of the ATF level is best done on a lift with the engine running in neutral and the ATF at a specific temperature.

WARNING —

The ATF should be warm when draining. Do not drain the ATF if the engine and/or transmission is hot. Hot ATF can scald.

1. Remove drain plug and drain fluid into container. See Fig. 28.

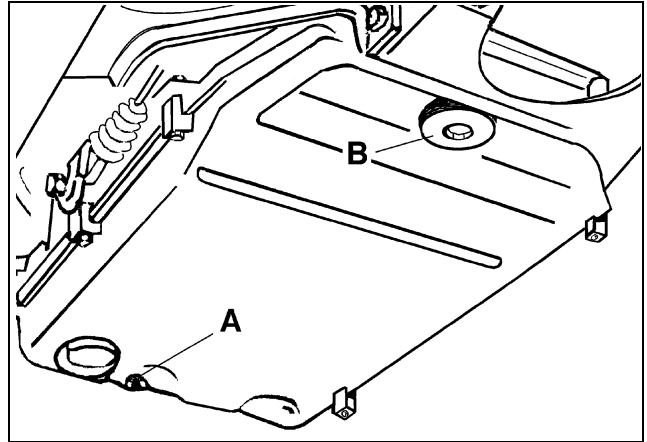

Fig. 28. Drain plug (A) and fill plug (B) on A5S 310Z transmission.

2. Remove oil sump mounting bolts and remove sump and sump gasket.
3. Remove strainer mounting screws and remove strainer.

NOTE —

Make sure the O-ring is attached to top of strainer when removing. See Fig. 24.

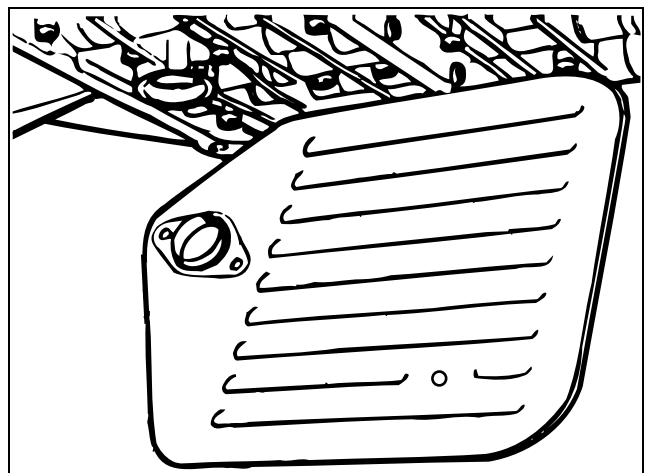

Fig. 29. ATF fluid strainer and O-ring on A5S 310Z transmission.

Installation is the reverse of removal. Always replace the drain plug seal and all gaskets and O-rings. Clean the sump and the sump magnets using a lint-free cloth. When mounting the sump, mount the curved sump clamping brackets at the front and rear corners of the sump. Mount the straight clamping brackets at the sump sides. The short legs on the clamps should contact the oil sump.

Fill the transmission with the specified amount of fluid using a suitable pump. The fluid level is correct when it begins to spill from the fill hole when the ATF temperature is at 30-55°C (86-131°F).

NOTE —

For the most accurate check of the ATF level, the car must be on level surface and unloaded, preferably on a lift. With the ATF at a temperature between 30-55°C (86-131°F), remove the ATF filler plug. Place the transmission in neutral and start the engine. Add ATF until it spills from the filler hole. Reinstall the filler plug.

Tightening Torques

- ATF drain plug to ATF sump 16 Nm (12 ft-lb)
- ATF strainer to valve body 5 Nm (44 in-lb)
- ATF sump to transmission 6 Nm (4 ft-lb)

ATF Specification

- Oil change volume (Dexron III)
- w/o torque converter 3.2 L (3.4 qt.)
- with torque converter 7.8 L (8.2 qt.)

ATF service—A5S 560Z

CAUTION —

The A5S 560Z uses a semi-synthetic ATF, only available from an authorized BMW dealer. Dexron must not be used in the A5S 560 Z transmission.

1. Remove drain plug and drain fluid into container.

WARNING —

The ATF should be warm when draining. Do not drain the ATF if the engine is hot. Hot ATF can scald.

2. Remove oil sump mounting bolts and remove sump and sump gasket.
3. Remove strainer mounting screws and remove strainer.

NOTE —

Make sure the O-ring is attached to top of strainer when removing. See Fig. 24.

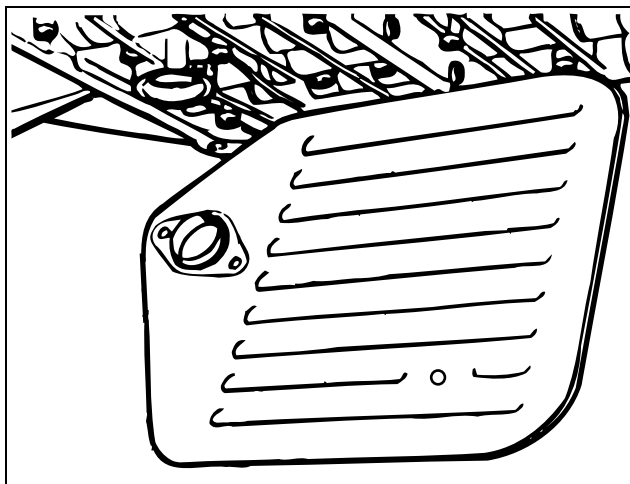

0011598

Fig. 30. ATF fluid strainer and O-ring on A5S 560Z transmission.

Installation is the reverse of removal. Always replace the drain plug seal and all gaskets and O-rings. Clean the sump, the expansion tank, and the sump magnets using a lint-free cloth. To remove the expansion tank, lift it straight off the sump.

The fluid level is correct when it begins to spill from the fill hole when the ATF temperature is between 30-50°C (86-122°F).

NOTE —

For the most accurate check of the ATF level, the car must be on level surface and unloaded, preferably on a lift. With the ATF at a temperature between 30-50°C (86-122°F), remove the ATF filler plug. Place the transmission in neutral and start the engine. Add ATF until it spills from the filler hole. Reinstall the filler plug.

Tightening Torques

- ATF drain plug to ATF sump 50 Nm (37 ft-lb)
- ATF strainer to valve body 5 Nm (44 in-lb)
- ATF sump to transmission 10 Nm (7 ft-lb)

ATF specification

- Oil change volume
BMW semi-synthetic fluid
(Shell LA 2634). 5.5 L (5.8 qt.)

CAUTION —

The A5S 560Z uses a special ATF, available from BMW. Dexron must not be used in the A5S 560Z transmission.